

Heavy Duty Driving Lights

ABL 3800 LED

- full LED combination drive light
- ECE homologated
- 5 functions integrated
- easy one to one halogen replacement



Heavy Duty - Driving Lights

ABL 3800 LED

The ABL 3800 LED combination drive light is an ECE approved full LED product designed for on-road and off-road vehicles. Along with numerous mounting operations, the high vibration performance of this full LED combination light allows industrial vehicles to endure extreme working conditions with virtual-free maintenance for their homologated driving lights package.

Dimensions

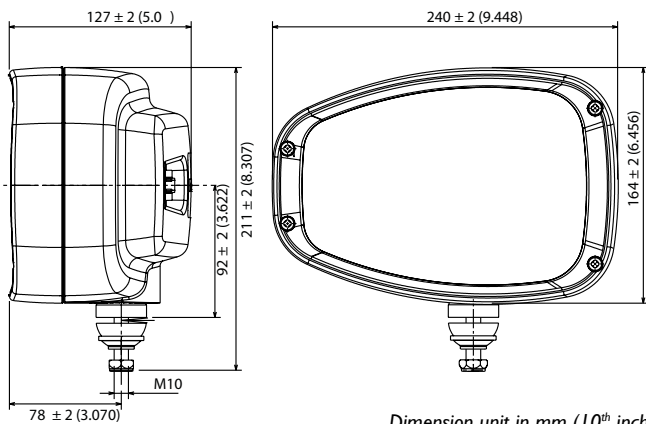

Dimension unit in mm (10th inch)



Specifications

Bulb	full LED modules
Lifetime	20 000 hours
Color temperature	6000°K
Light pattern	ECE R112 High / Low Beam ECE R6 Turn Signal and Repeater ECE R7 PiLot Light
Consumption	22W High Beam, 32W Low Beam
Voltage	Multi 12-24V
Intensity	1,29 Amp @ 24V (Low Beam) 0.85 Amp @ 24V (High Beam)
Weight	1,95 Kg
Vibration resistance	15 Grms from 24 to 2000Hz
Shock resistance	60 G
EMC	ISO 13 766 - ISO 14 982 - ISO 12 895 - CISPR25 Class3
Load Dump	36V continuous 72V 100 ms 1800 V 50 μs
Polarity	protected against reverse voltage
Electronic Thermal Management	protected against over heating
Water Tightness	IP 68 - IP 69K
Operating Temp	-40°C to +85°C
Salt Spray	ISO 9227
Lens	hardened glass
Reflector	free form reflectors and aspherical lenses modules
Warranty	20 000 operating hours or 4 years

Connection



Built-in DT
6 ways

Cable
compression seal
PGI 1

Mounting

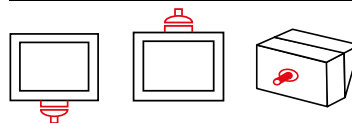

Pedestal swivel

Suspended swivel

Rear Swivel